

Come mai da millenni stiamo tutti
col naso all'insù?

Emanuele Salerno

21/03/2005

- La storia inizierebbe circa tredici miliardi e mezzo di anni fa
- Ma partiamo dal 1915 (con qualche breve flashback)

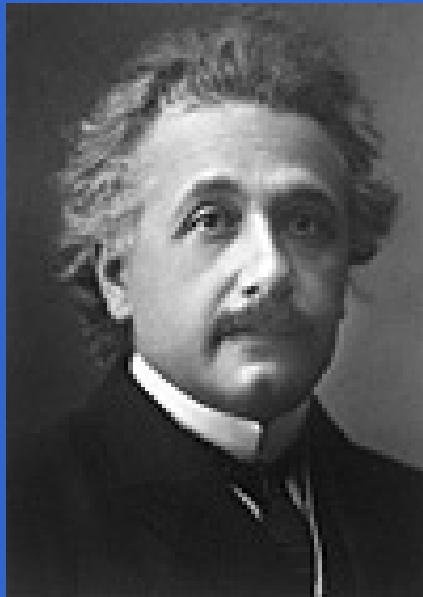

Albert Einstein introduce la costante cosmologica nelle equazioni della relatività generale che descrivono la nuova gravitazione universale (in qualche modo questo universo bisognerà tenerlo fermo)

Lo studio dell'universo nel suo insieme è da millenni materia per filosofi speculativi, e lo rimarrà ancora per qualche decennio

1929

- Edwin Hubble scopre che l'universo è in espansione



Ho trovato una costante anch'io!

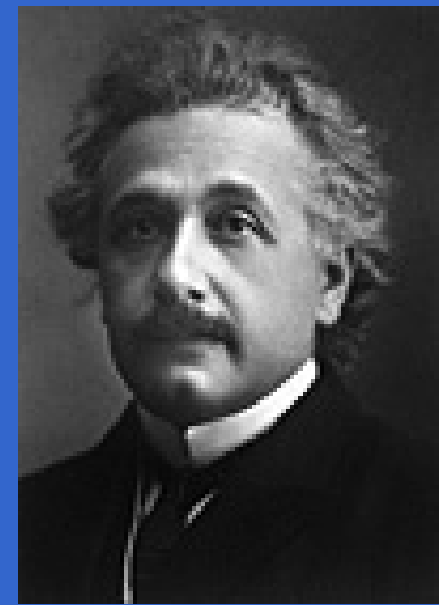

Il più grave errore
della mia vita

1927

- Georges Lemaître propone la teoria del Big Bang

C'è stato un giorno senza ieri

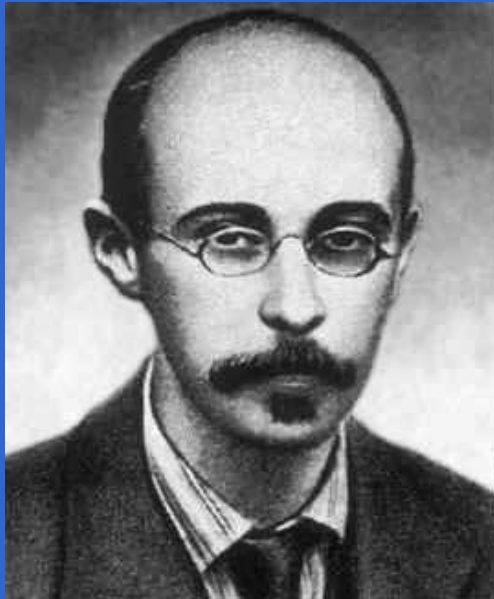

Anche Alexander Friedman lo aveva ipotizzato cinque anni prima

1948

- George Gamow prevede l'esistenza della radiazione cosmica di fondo



Un botto tale deve pure aver fatto qualche danno

Se c'è stato il Big Bang dovremmo essere immersi in una radiazione di corpo nero perfettamente isotropa alla temperatura di circa 3K

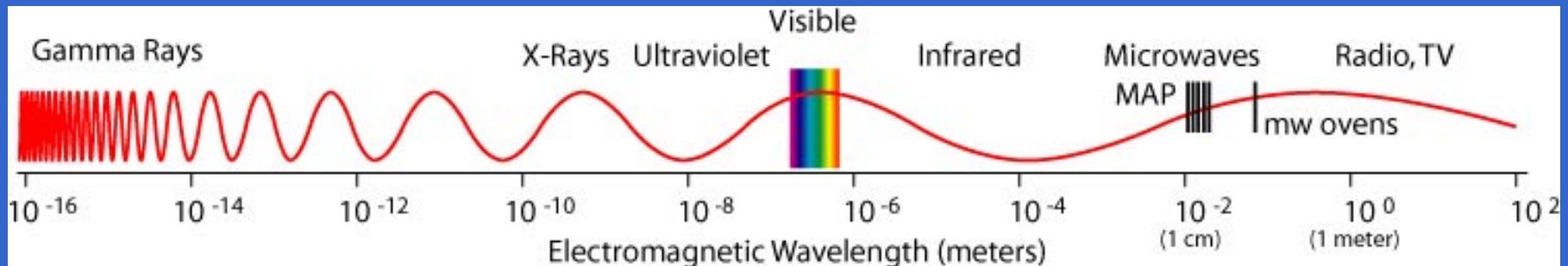

1964

- Arno Penzias e Robert Wilson scoprono la radiazione cosmica di fondo a microonde



Ma cos'ha quest'antenna?

Nasce la cosmologia come scienza sperimentale

Ma la prima luce non è stata emessa all'istante del big bang

Quando è stata emessa l'universo aveva già cominciato a differenziarsi. La temperatura vista da un'antenna non sarà esattamente la stessa in tutte le direzioni

Conoscere la mappa delle temperature su tutta la sfera celeste sarebbe utilissimo per provare (o smentire) la fondatezza delle nostre teorie sull'universo

Prima teoria: $\Delta T/T \cong 10^{-2}$

Nulla

Seconda teoria: $\Delta T/T \cong 10^{-3}$

Nulla

Terza teoria:

Nulla!



PLANCK

2002

WMAP

Wilkinson Microwave Anisotropy Probe

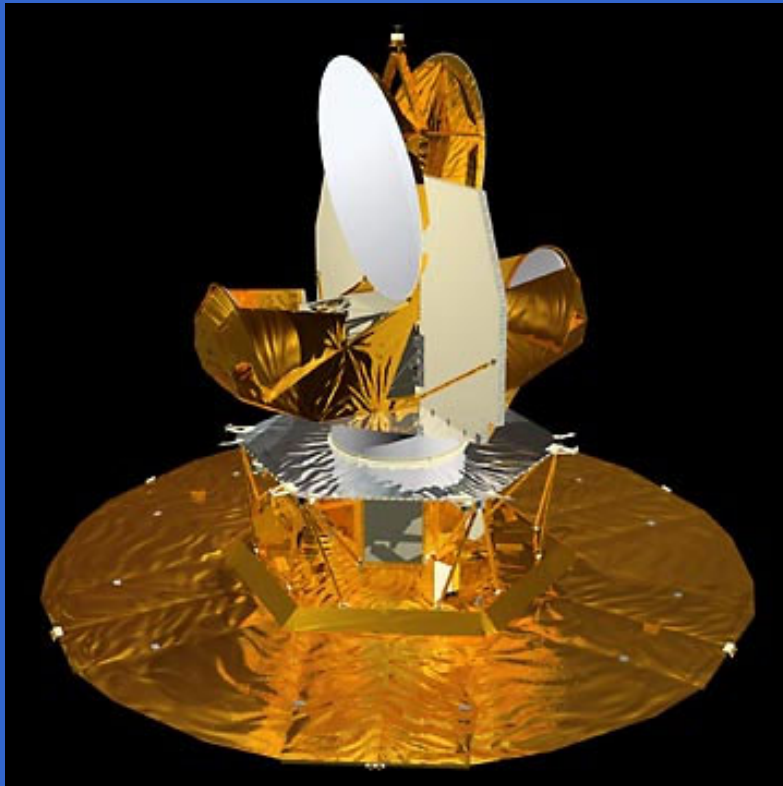

Charles Bennett

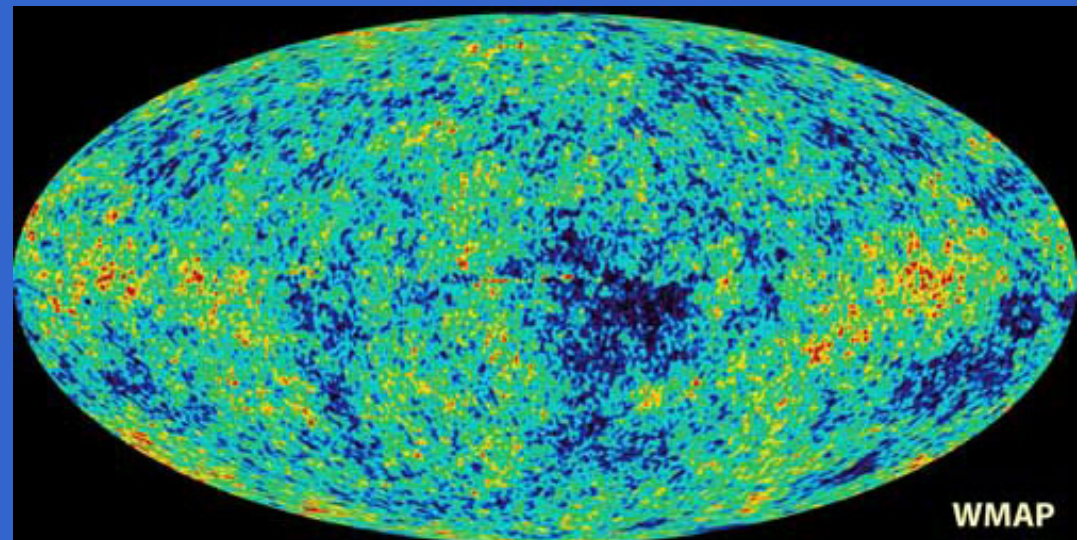

2007:

PLANCK

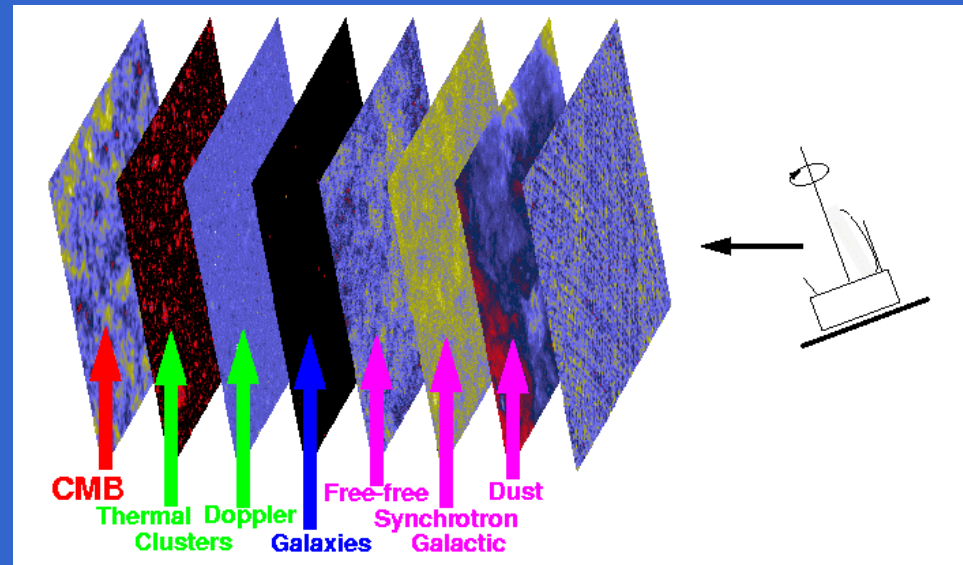
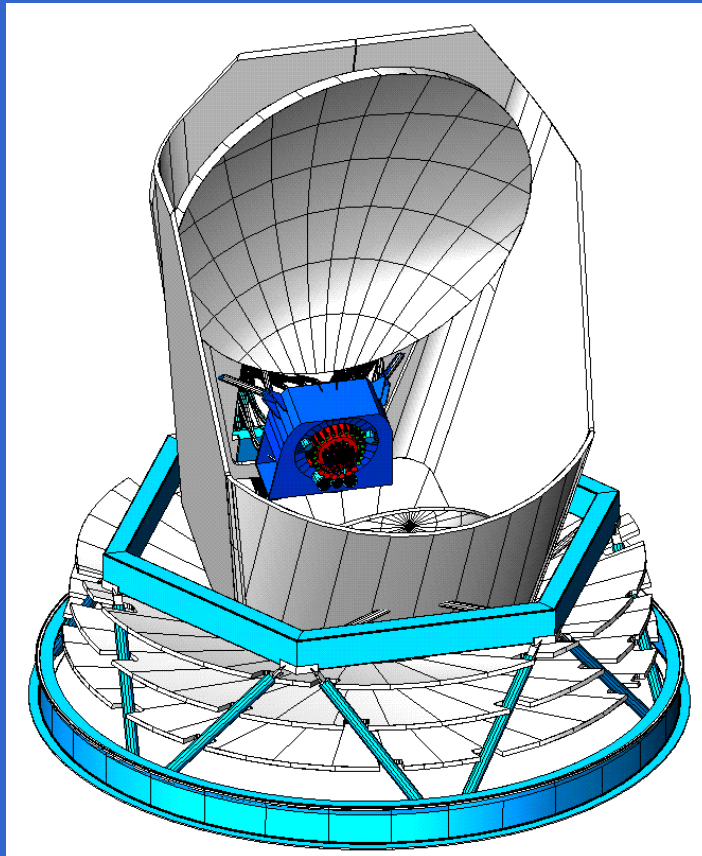

Guardare nel passato con un dettaglio mai raggiunto

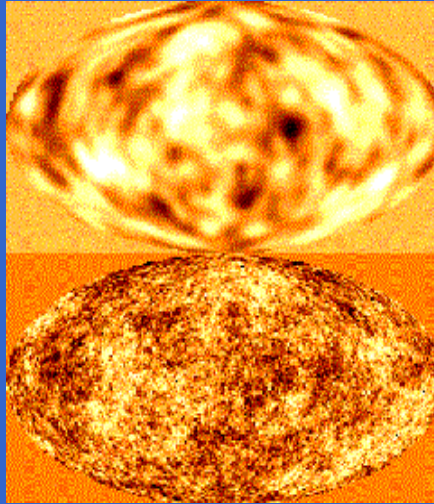

Comparison between **CMB** maps for **COBE** (above) and **Planck** (below, simulated from a cold-dark matter inflationary model). Temperature differences across the sky are measured by Planck with a precision of two parts in a million and an angular resolution of $10'$

Values of **cosmological parameters** can be determined by comparing model and observed temperature power spectra - for instance, the influence of the **Hubble constant** on the power spectrum is shown here.

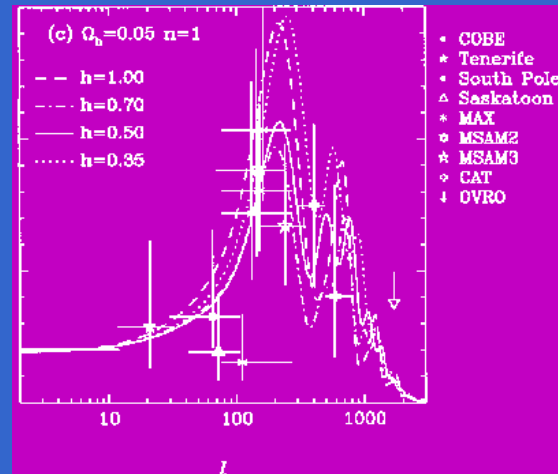

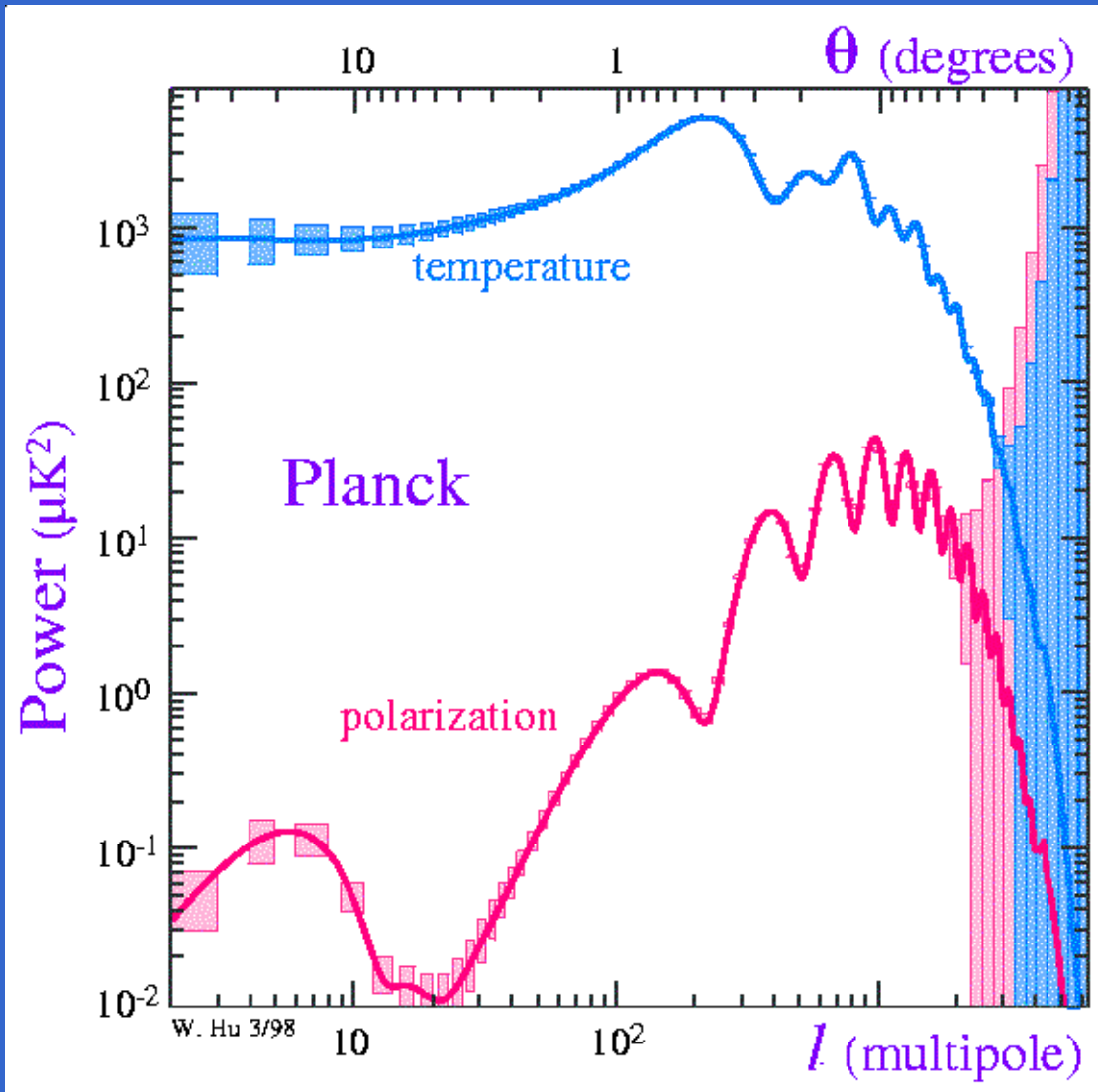

A number of radiometers with frequency responses $b_d(\nu)$ on M different channels measure the total radiation, giving M different noisy outputs

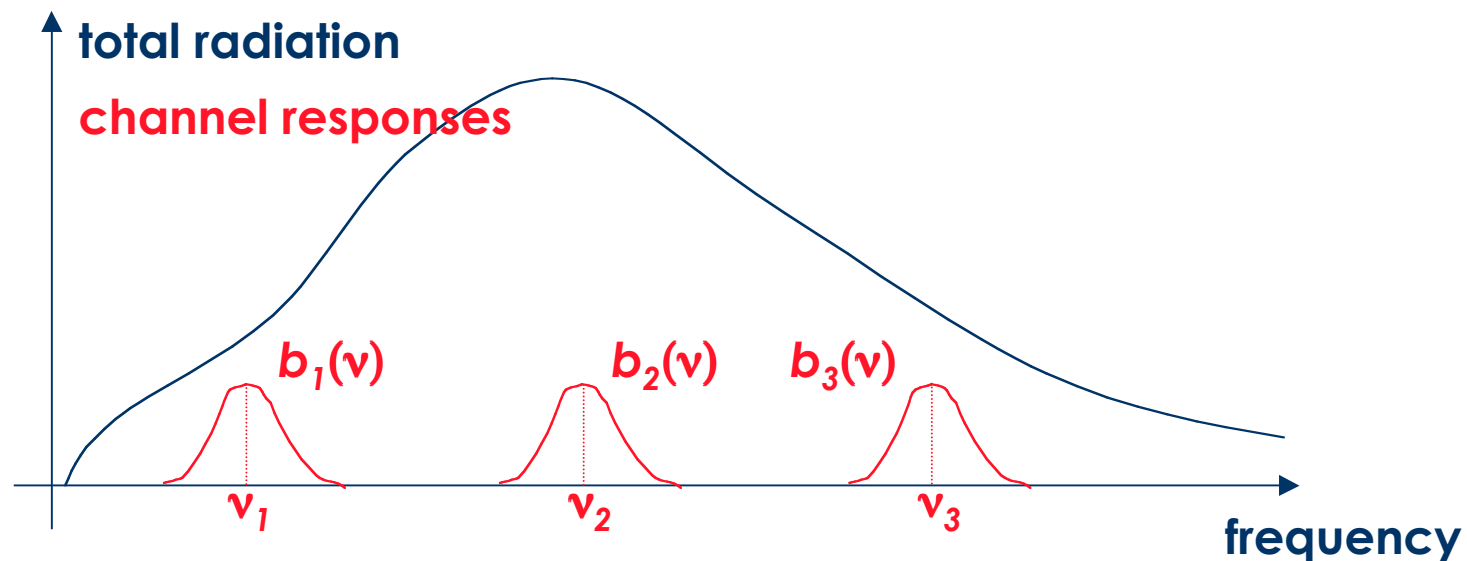

Each output is the integral of the product between the total radiation spectrum and one of the frequency responses of the instrument, corrupted by instrumental noise

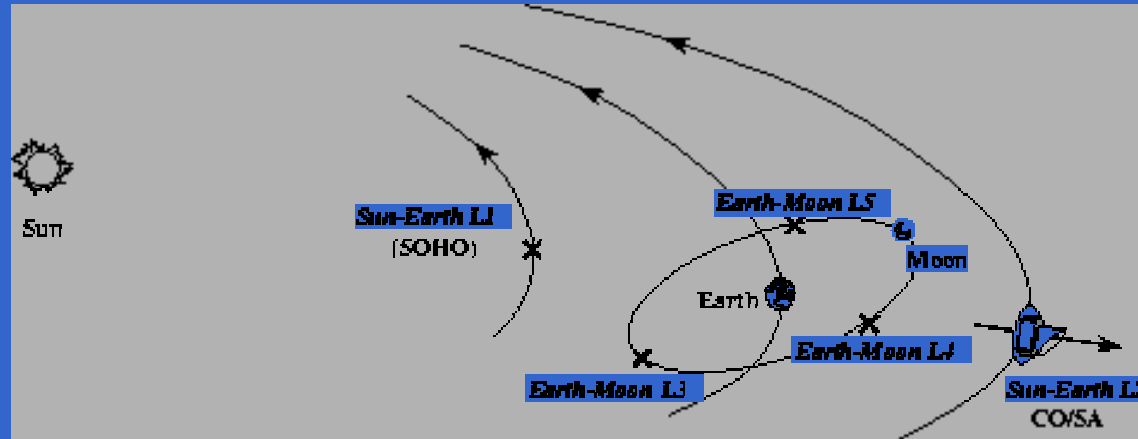

Il secondo punto lagrangiano del sistema Terra Sole (L2) si trova a 1.500.000 chilometri dalla Terra, ed è costantemente allineato con la congiungente Terra-Sole

Orbita di *Planck* attorno a L2

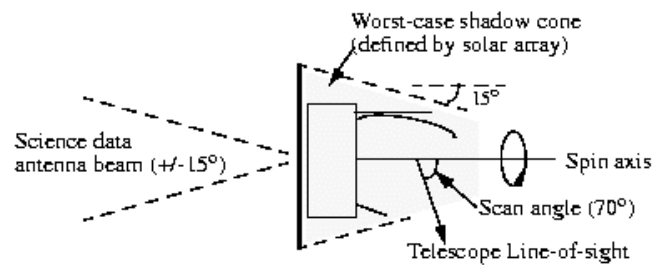
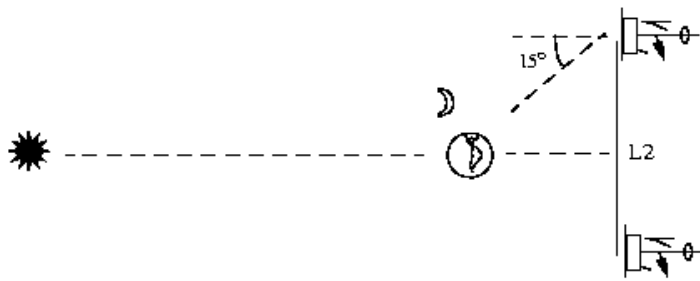
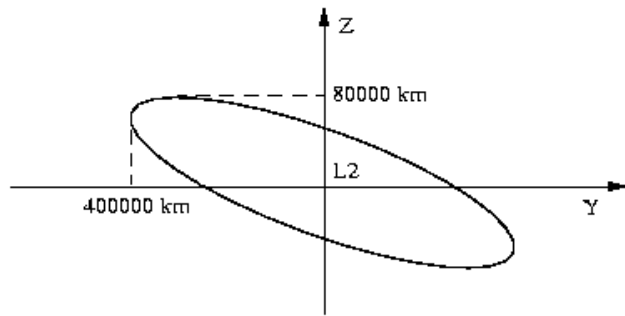

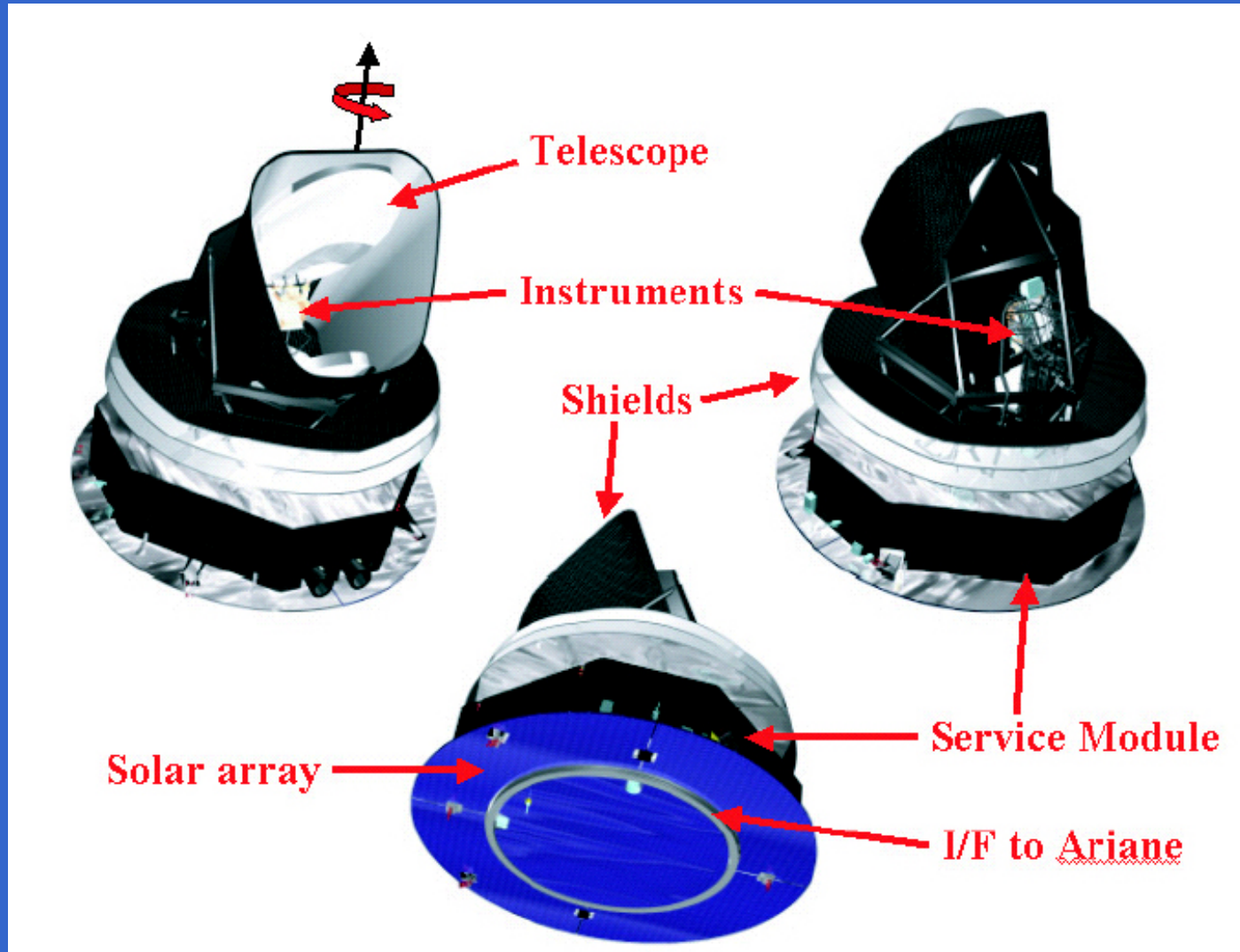



Telescopio

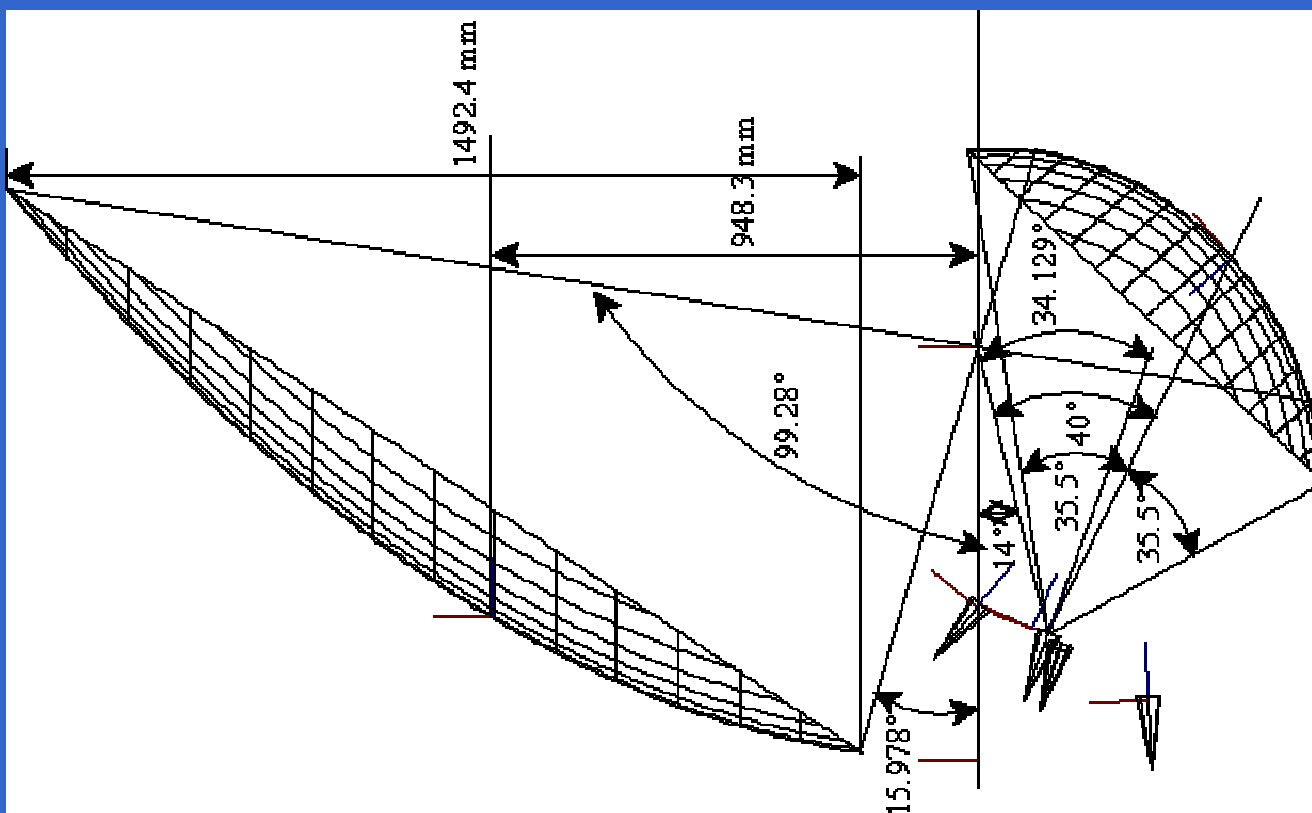

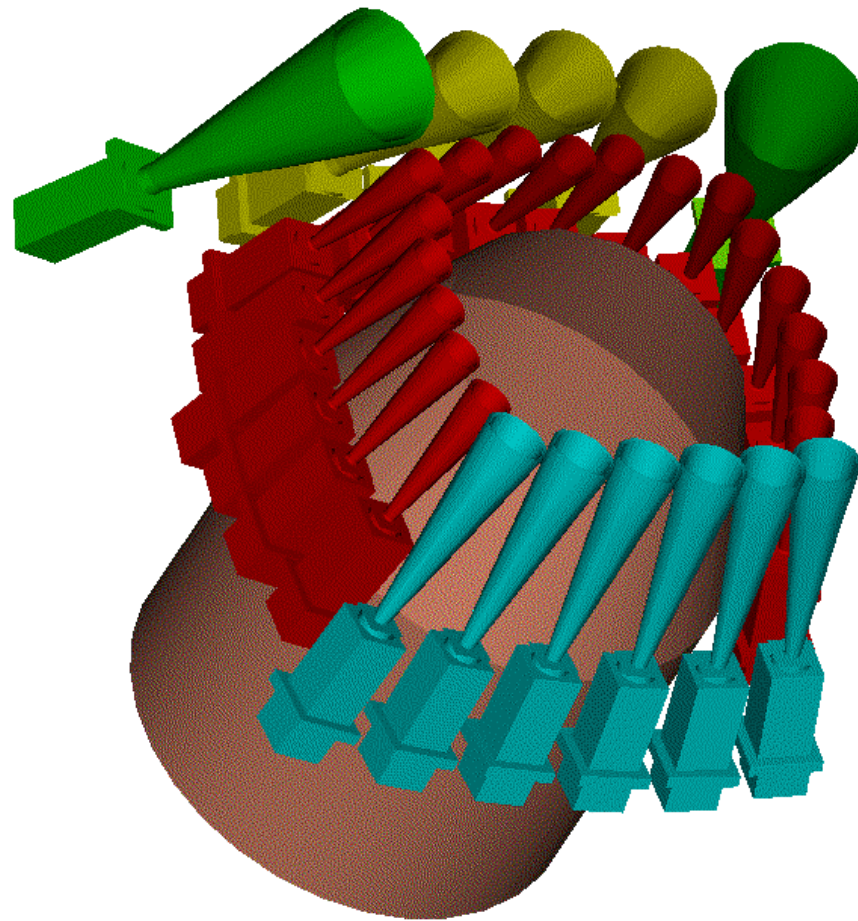

Front end strumento a bassa frequenza (vecchia versione)

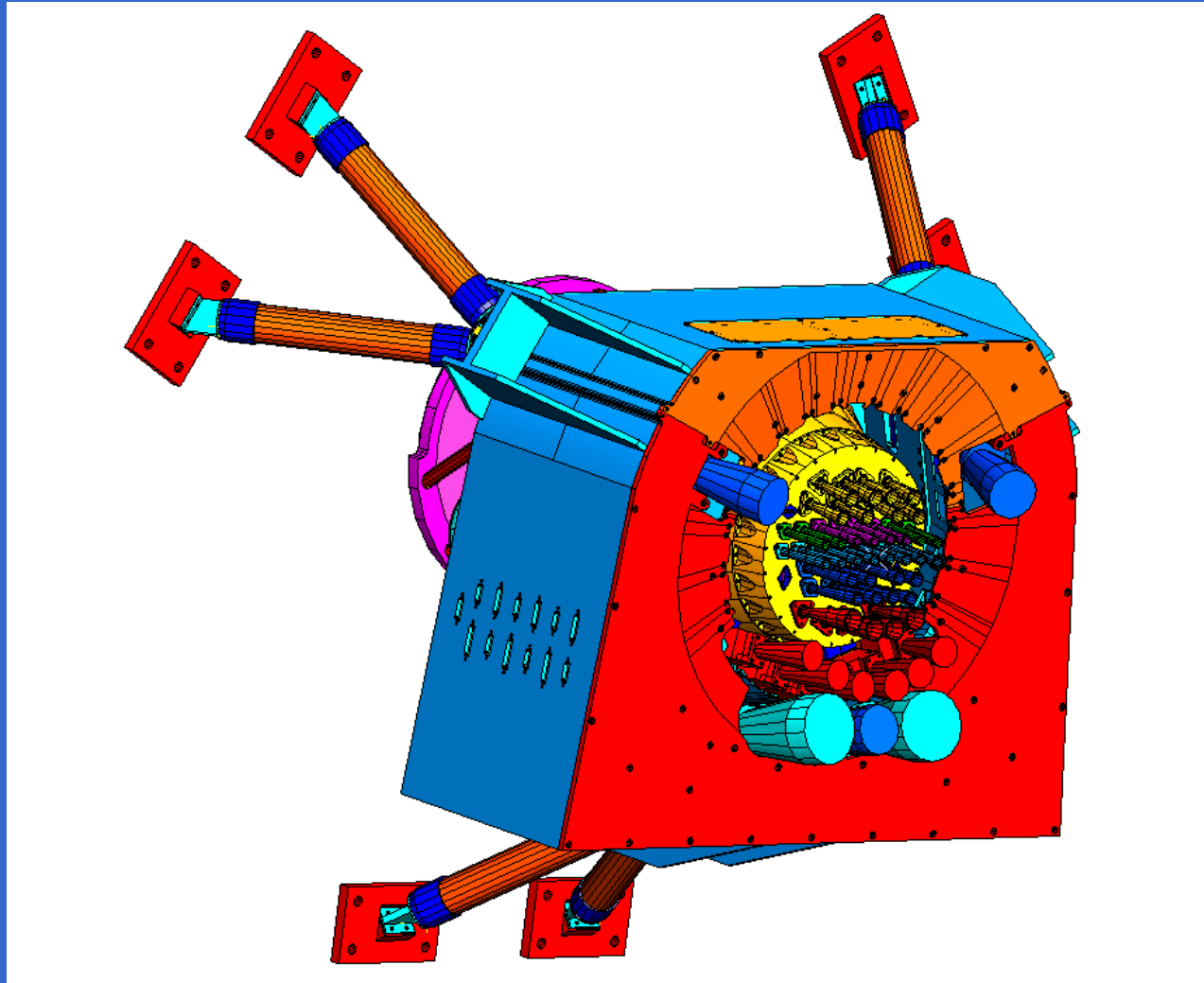

Versione attuale strumenti ad alta e bassa frequenza (30-857 GHz)

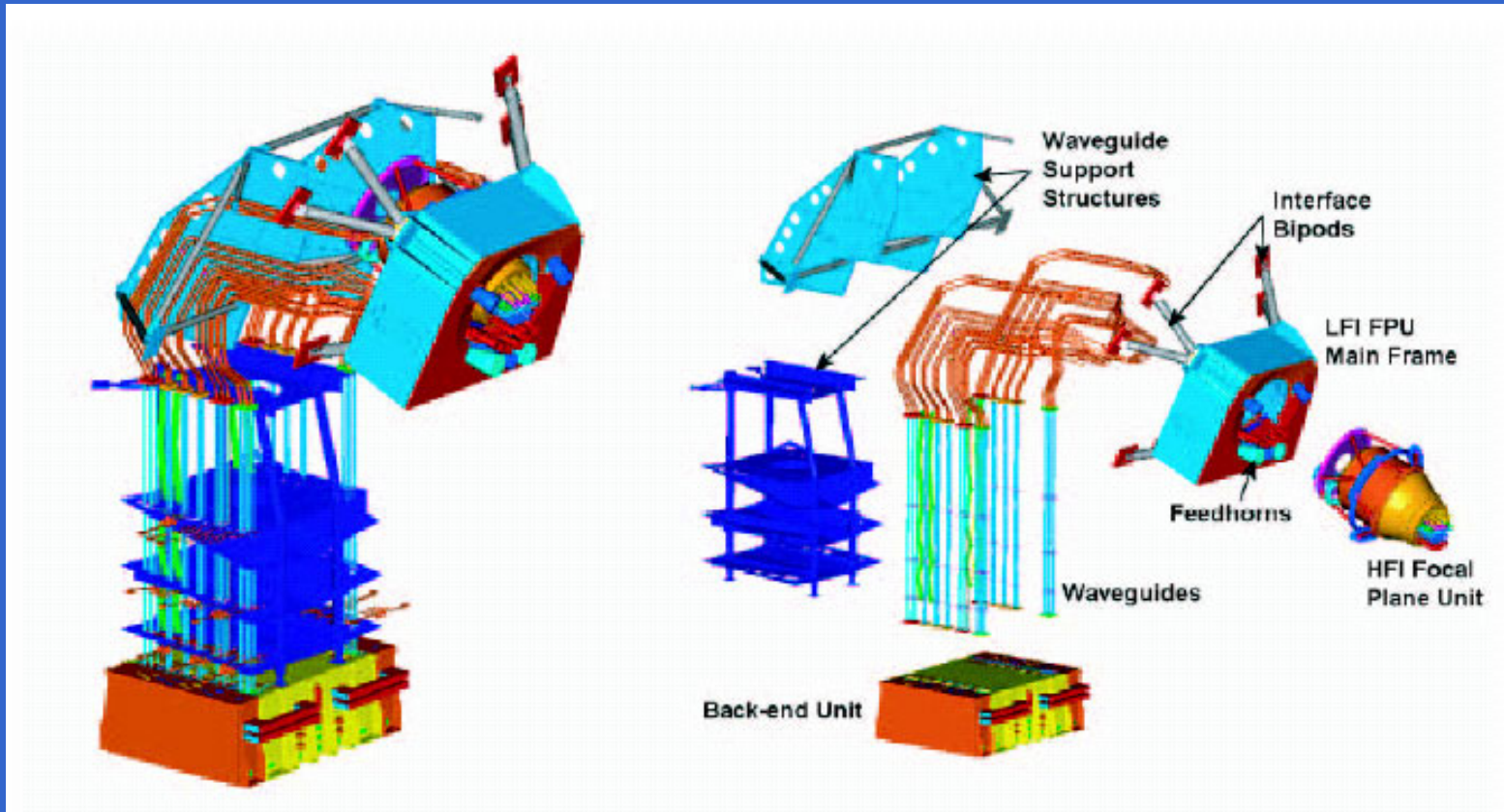

Collegamento front-end back-end in guida d'onda

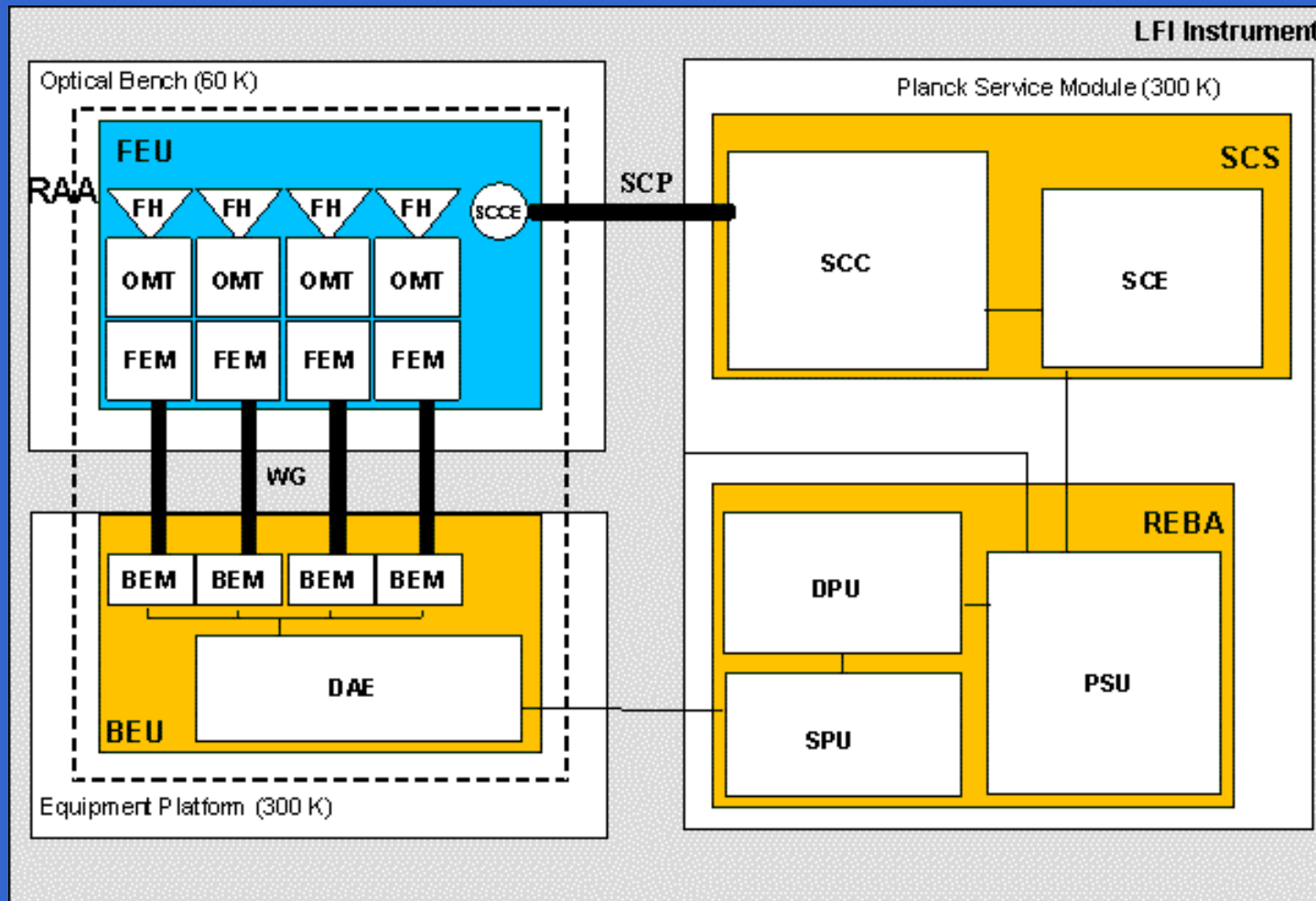

Schema strumento a bassa frequenza (30-44-70 GHz)

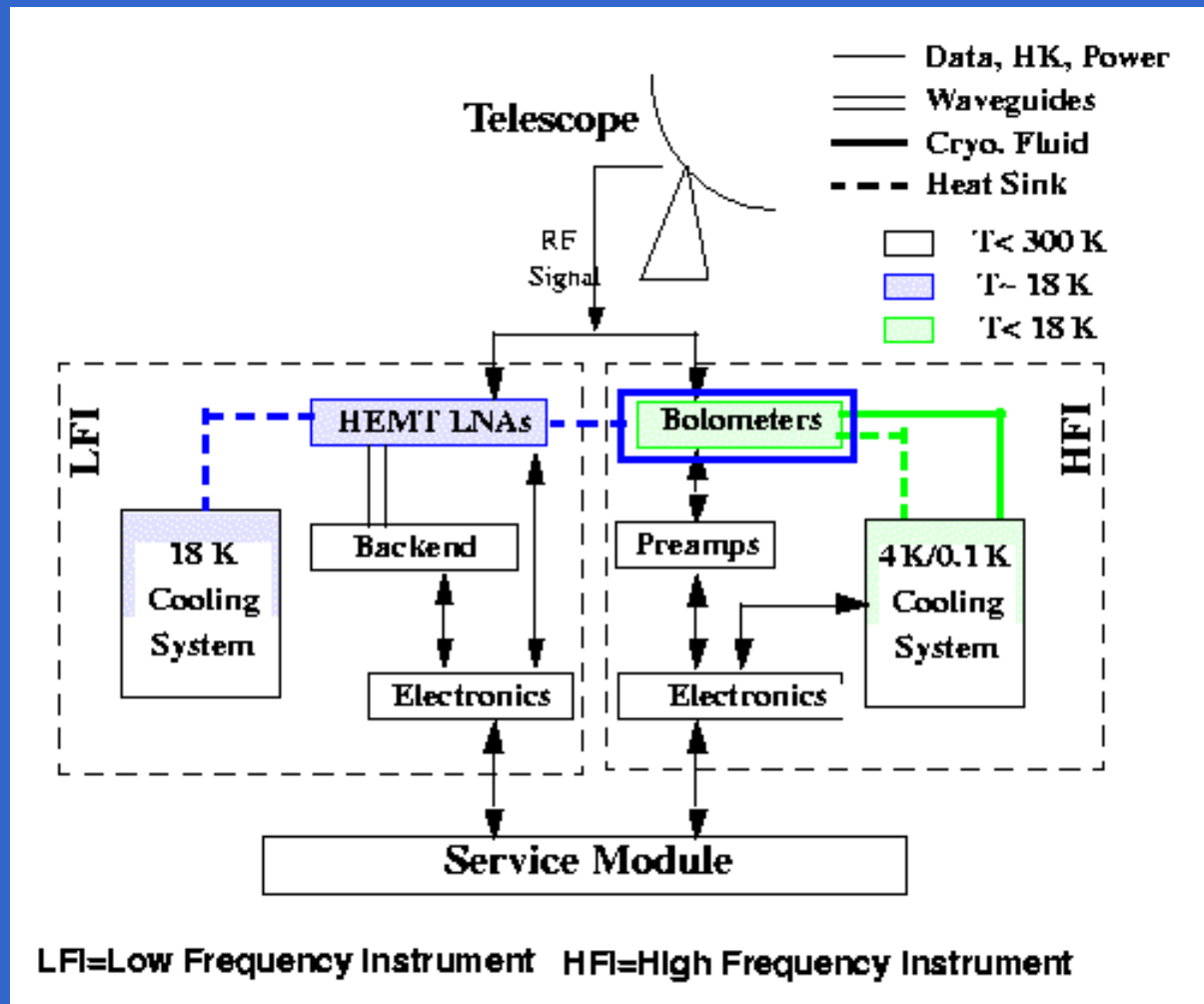

LFI=Low Frequency Instrument HFI=High Frequency Instrument

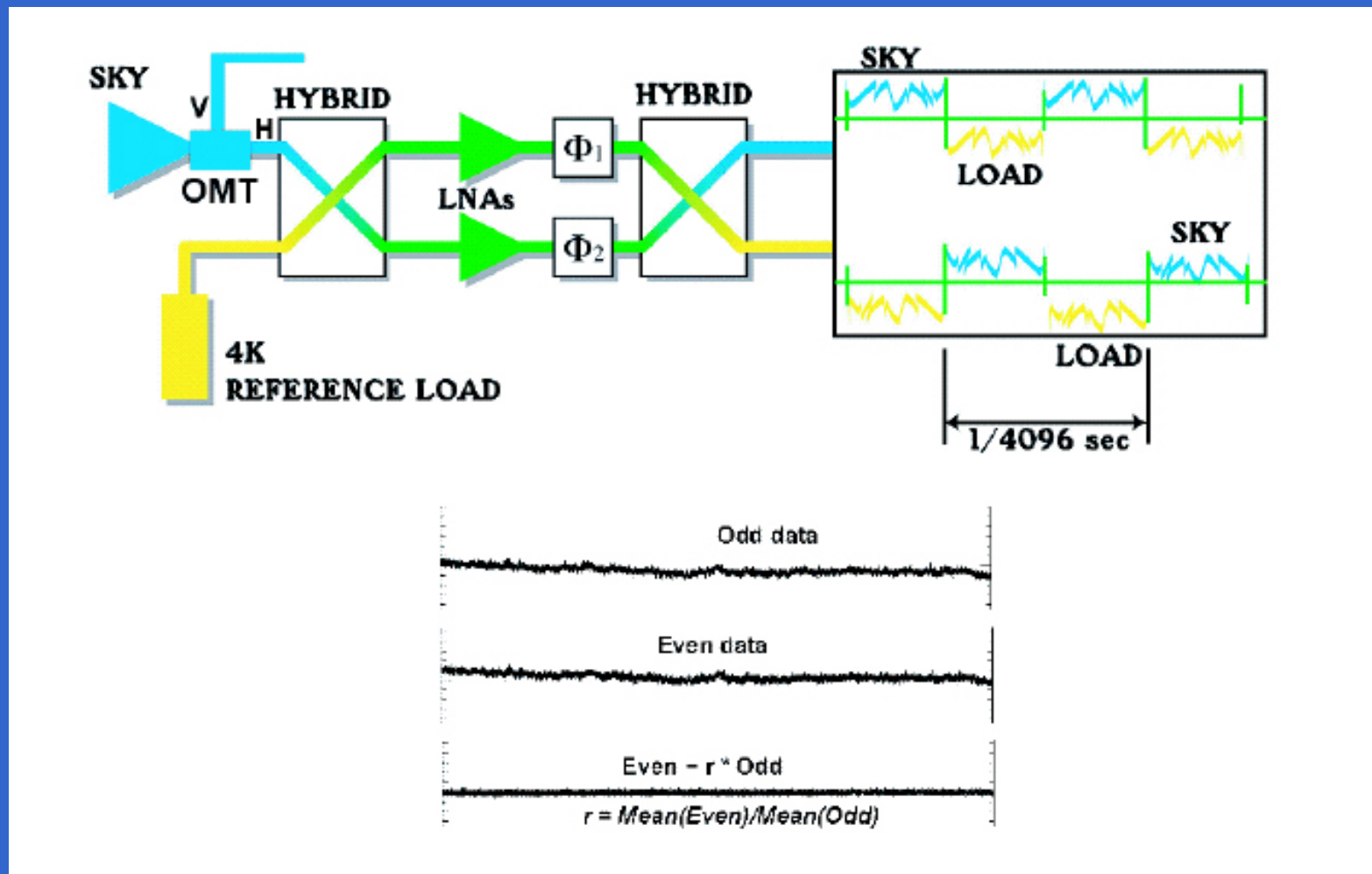

Schema di misura strumento a bassa frequenza



PLANCK

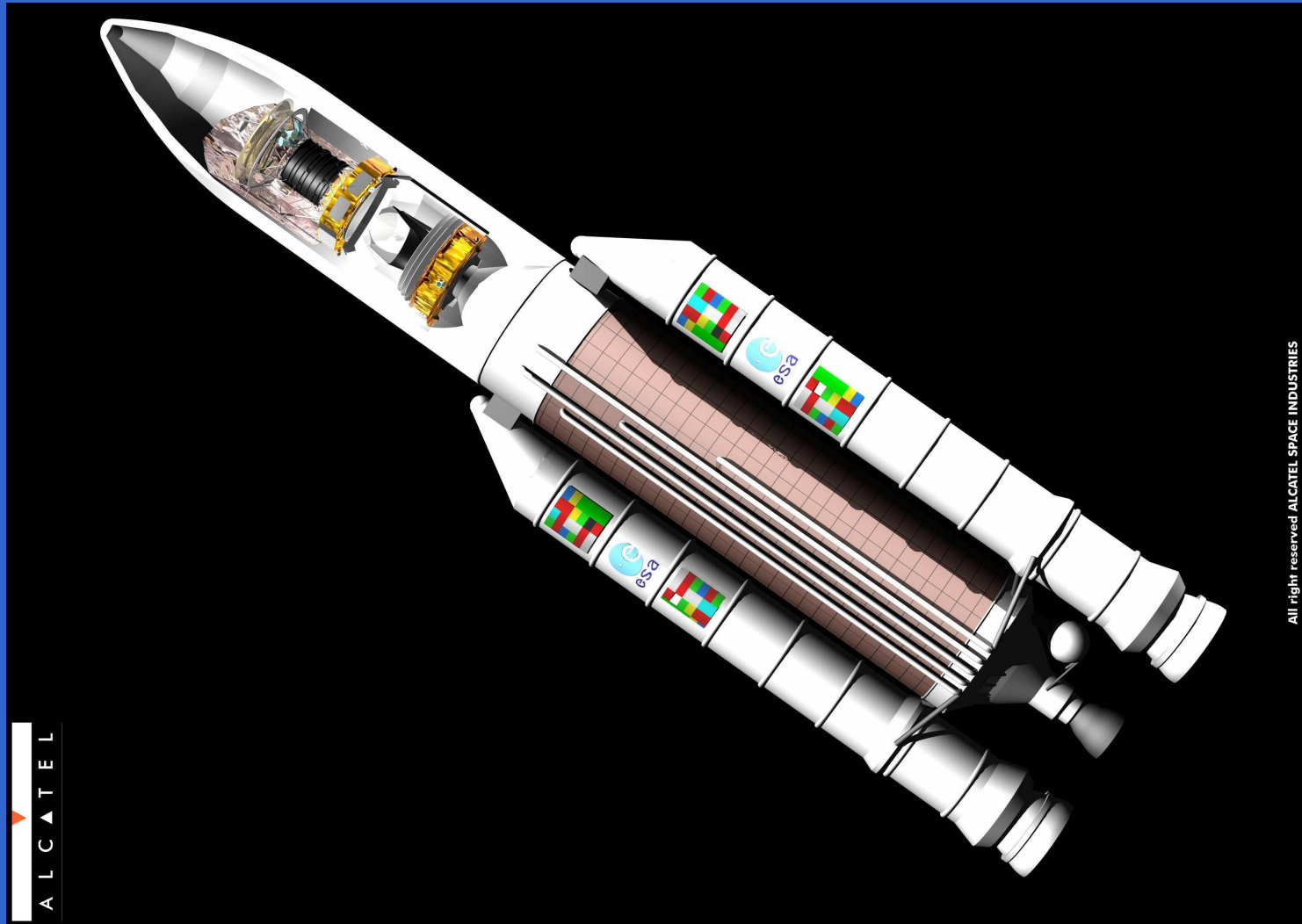

Planck e Herschel su Ariane V



PLANCK

FINE

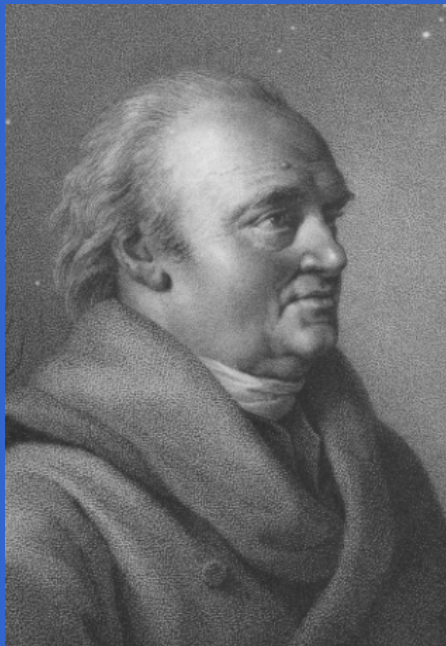

Herschel



Planck